

บ็อกลม ญี่ปุ่น "T & G" (IMTEC)

T&G CORPORATION 3/8" and 1/2" SQ.DR. IMPACT WRENCHES

SQ. 3/8"



TG-1355

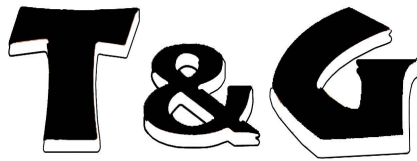

PNEUMATIC TOOLS

รหัสสินค้า	รุ่น	ระบบ	ตัวละ
TG1355	TG - 1355	Pin Clutch	

* W / Socket 8, 10, 12, 14

SQ. 1/2"



TG-1665M
TG-1665ML (3")



TG-1566M

รหัสสินค้า	รุ่น	ระบบ	ตัวละ
TG1566	TG-1566M	Maurer	
TG1665M	TG-1665M	Maurer	
TG1665M	TG-1665ML	Maurer	

* W / Socket 14, 17, 19, 21

ตัวเล็กทำด้วยไฟเบอร์

SQ. 1/2"



TG-1650A

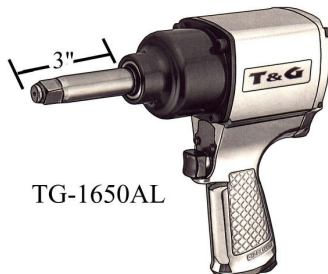

TG-1650AL

รหัสสินค้า	รุ่น	ระบบ	ตัวละ
TG1650	TG-1650A	Twin Hammer	
TG16502	TG-1650AL	Twin Hammer	

* W / Socket 14, 17, 19, 21

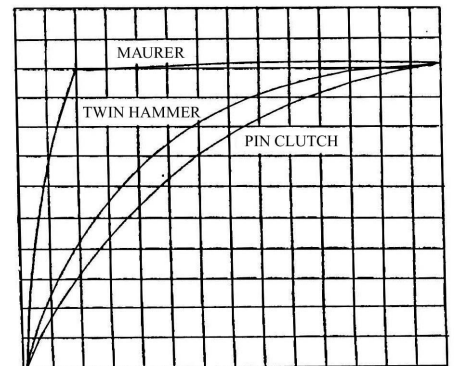
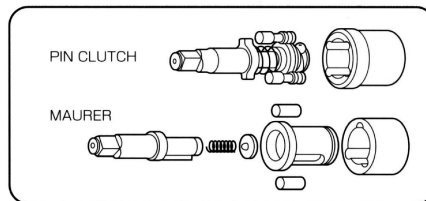
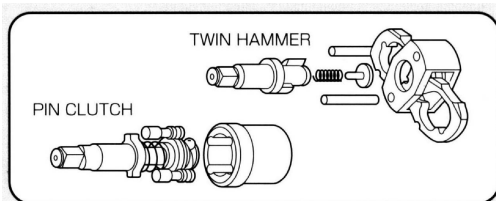
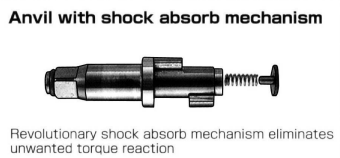

* SPECIFICATIONS (FT/LB x 0.1383 = M.Kg) (M.Kg x 7.233 = FT/LB)

Model Number	Capacity Bolt Size	Sq. Drive	Type of Clutch	Free Speed	Max. Torque	Recommended Operating Torque	Length	Weight	Avg. Air Consumption	Air Inlet Size
	mm	in.		r.p.m.min	ft-lb	ft / lb			C.F.M.	
TG-1355	10	3/8"	Pin Clutch	8,500	120	50 - 100	159	1.7	3.5	1/4" NPT
TG-1566M	16	1/2"	Maurer	7,000	550	50 - 380	197	2.2	4.4	1/4" NPT
TG-1650A	16	1/2"	Twin Hammer	8,000	480	50 - 380	190	2.6	4.4	1/4" NPT
TG-1650AL	16	1/2"	Twin Hammer	8,000	440	50 - 360	243	2.7	4.4	1/4" NPT
TG-1665M	16	1/2"	Maurer	7,000	500	50 - 380	190	2.4	4.4	1/4" NPT
TG-1665ML	16	1/2"	Maurer	7,000	480	50 - 360	242	2.5	4.4	1/4" NPT

** ดูคู่มือที่แถมให้อาจมีการเปลี่ยนแปลง **

www.boriphat.com

ราคานี้ยังไม่รวมภาษีมูลค่าเพิ่ม

ราคาอาจเปลี่ยนแปลงได้โดยมิต้องแจ้งล่วงหน้า

บ็อกลม ญี่ปุ่น "T & G" (IMTEC)

T&G CORPORATION 3/4" and 1" SQ.DR. IMPACT WRENCHES

SQ. 3/4"

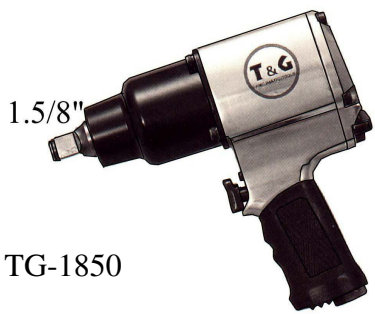

TG-1850

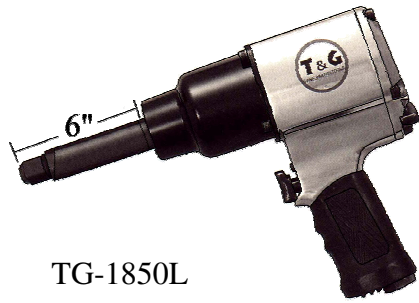

TG-1850L

(W / Socket 19, 21, 23, 24)

รุ่น	ตัวละ
TG - 1850	

รุ่น	ตัวละ
TG - 1850L	

SQ. 1"

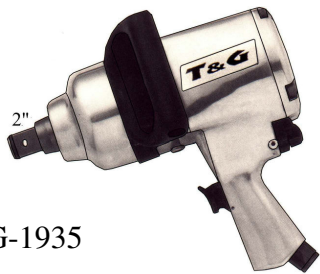

TG-1935

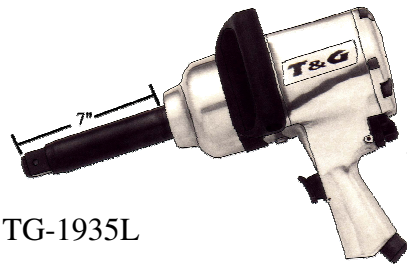

TG-1935L

(W / SOCKET □ 21, 35, 38, 41WA)

รุ่น	ตัวละ
TG - 1935	

รุ่น	ตัวละ
TG - 1935L	

SQ. 1"

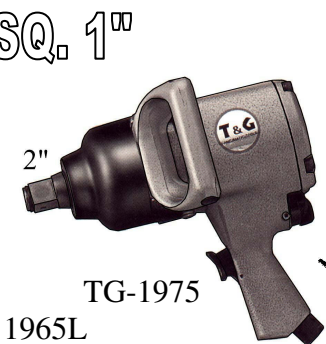

TG-1975
1965L

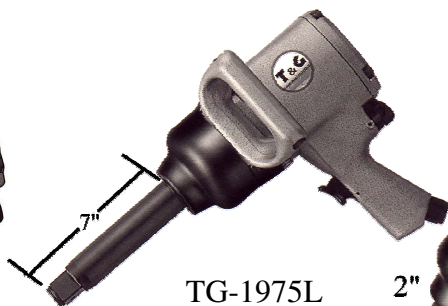

TG-1975L

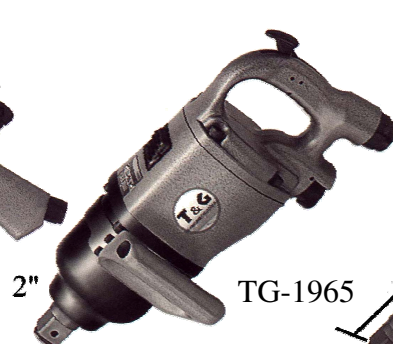

TG-1965

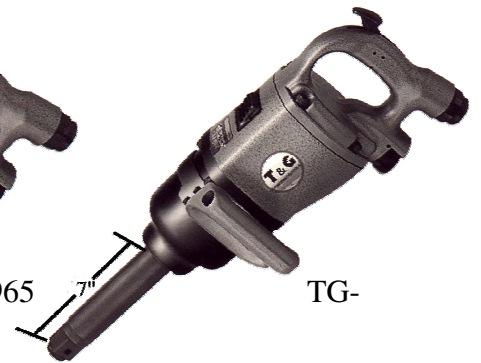

TG-1965L

(W / Socket □ 21, 35, 38, 41WA)

รุ่น	ตัวละ
TG-1975	

รุ่น	ตัวละ
TG-1975L	

รุ่น	ตัวละ
TG-1965	

รุ่น	ตัวละ
TG-1965L	

Model Number	Capacity Bolt Size	Sq. Drive	Type of Clutch	Free Speed	Max. Torque	Recommended Operating Torque	Length	Weight	Avg. Air Consumption	Air Inlet Size
	mm	in.		r.p.m.min	ft-lb	ft / lb			C.F.M.	
TG-1850	22	3/4"	Pin Clutch	5,000	1,200	300 - 800	260	5.7	5.8	3/8" NPT
TG-1850L	22	3/4"	Pin Clutch	5,000	1,200	300 - 800	412	6.4	5.8	3/8" NPT
TG-1935	42	1"	Pin Clutch	4,000	2,169	10 - 1,250	290	10.0	11.3	1/2" NPT
TG-1935L	42	1"	Pin Clutch	4,000	2,097	10 - 1,200	400	11.0	11.3	1/2" NPT
TG-1965	45	1"	Pin Clutch	4,000	3,000	600 - 1,400	410	11.6	9.0	1/2" NPT
TG-1965L	45	1"	Pin Clutch	3,800	2,700	500 - 1,300	535	12.7	9.0	1/2" NPT
TG-1975	45	1"	Pin Clutch	4,000	2,800	600 - 1,400	302	11.3	8.5	1/2" NPT
TG-1975L	45	1"	Pin Clutch	3,800	2,500	500 - 1,300	429	12.4	8.5	1/2" NPT

Specifications: (M.KG x 7.233 = FT/LB) (FT/LB x 0.1383 = M.KG)

** ดูบ็อกที่แถมให้อาจมีการเปลี่ยนแปลง **

www.boriphat.com

ราคานี้ยังไม่รวมภาษีมูลค่าเพิ่ม

ราคาอาจเปลี่ยนแปลงได้โดยมิต้องแจ้งล่วงหน้า